

HF Series-High Frequency Mini Parts Drive Units

Feature

For handling a wide range of very small and ultra thin sized parts and electronics chips. Compact design and versatility to handle a wide range of small parts. These bowl parts feeders provide high-speed and high-precise with high vibration frequency of 150 to 360Hz and small amplitude, this series is ideal for very small parts (10 mm or less) smooth delivery.

Order Code

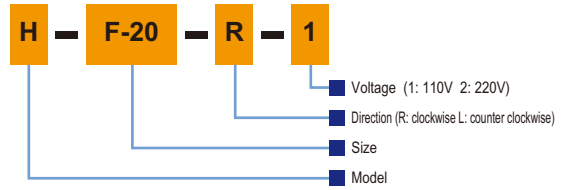

Dimension

Model	H	ØA	ØB	C	D	M	R
HF-20	84	140	120	6	9	M8	83
HF-25	105	190	160	6	9	M8	106

Unit mm



HF-20

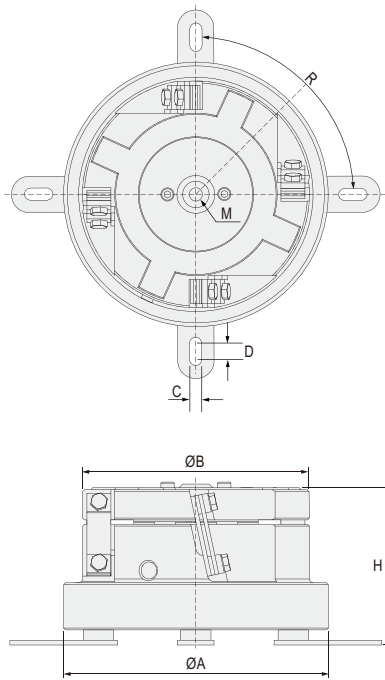

HF-25

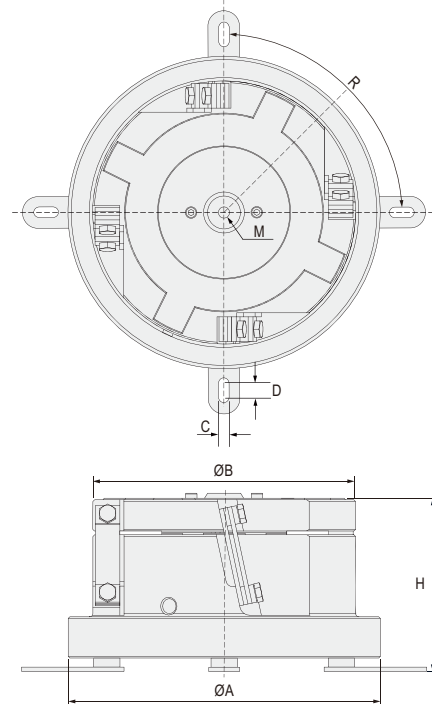

Specifications

Specifications Model	Rated Voltage (V)	Rated Current (A)	Vibration Frequency (Hz)	Vibration Cycles/Min	Mass (kg)	Applicable Control Unit	Applicable Bowl
HF-20 ^R ① ②	AC110/220	0.5/0.25	150/360	9000~21600	3.0	EC30-1DF/EC30-1SDF	Ø 130~180mm
HF-25 ^R ① ②	AC110/220	0.8/0.4	150/360	9000~21600	3.8	EC30-1DF/EC30-1SDF	Ø 170~250mm